

YJF-11025 罩极电机 Shaded Pole Motors

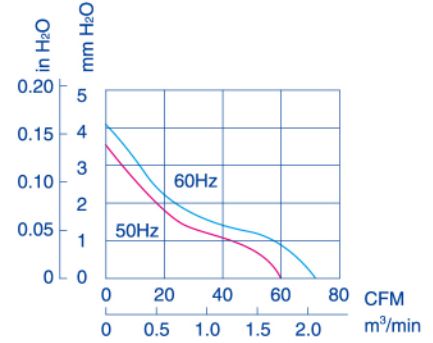

TYPE 型号	BEARING 轴承	LEAD WIRE 引出线	VOLTAGE 额定电压 V	FREQUENCY 额定频率 Hz	RATED INPUT 额定功率 W	RATED CURRENT 额定电流 A	SPEED 额定转速 r/min	AIR VOLUME 额定风量		STATIC PRESSURE 静压 mmH ₂ O	NOISE 噪音 dBA	NET WEIGHT 净重 kg	LICENSE 认证
								m ³ /min	CFM				
11025HB	BALL	CABLE	220~240	50/60	12/10	0.065/0.055	1900	1.22	43	3.00/2.60	36	0.33	CE
11025HS	SLEEVE	CABLE	220~240	50/60	12/10	0.065/0.055	1700	1.16	41	3.10/2.90	34	0.33	CE
11025HB	BALL	CABLE	110~120	50/60	15/12	0.17/0.14	2100/2300	1.33/1.47	47/52	3.56/4.06	38/40	0.33	CE
11025HS	SLEEVE	CABLE	110~120	50/60	15/12	0.17/0.14	2100/2300	1.33/1.47	47/42	3.56/4.06	38/40	0.33	CE

YJF-12025 罩极电机 Shaded Pole Motors

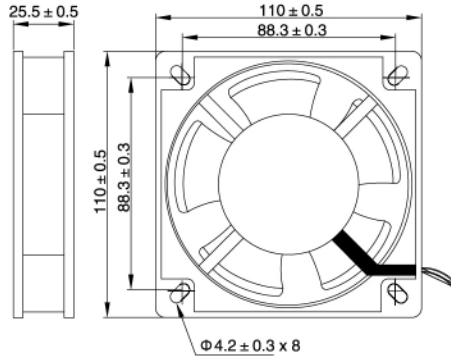
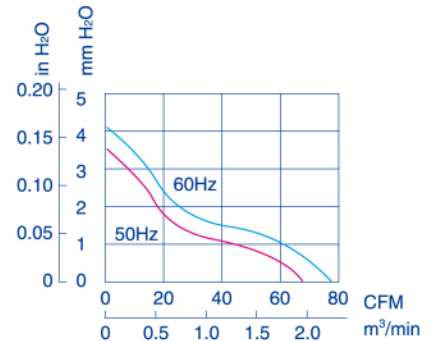
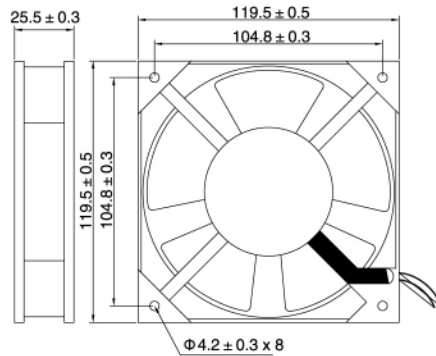

TYPE 型号	BEARING 轴承	LEAD WIRE 引出线	VOLTAGE 额定电压 V	FREQUENCY 额定频率 Hz	RATED INPUT 额定功率 W	RATED CURRENT 额定电流 A	SPEED 额定转速 r/min	AIR VOLUME 额定风量		STATIC PRESSURE 静压 mmH ₂ O	NOISE 噪音 dBA	NET WEIGHT 净重 kg	LICENSE 认证
								m ³ /min	CFM				
12025HB	BALL	CABLE/TERMINAL	220~240	50/60	12/10	0.065/0.055	1950	1.58	56	2.60/2.30	38/40	0.33	CE UL
12025HS	SLEEVE	CABLE/TERMINAL	220~240	50/60	12/10	0.065/0.055	1700	1.39	49	2.70/2.40	36/38	0.33	CE UL
12025HB	BALL	CABLE/TERMINAL	110~120	50/60	19/18	0.19/0.18	2200/2400	1.78/1.95	63/69	3.50/4.10	38/40	0.33	CE UL
12025HS	SLEEVE	CABLE/TERMINAL	110~120	50/60	19/18	0.19/0.18	2200/2400	1.78/1.95	63/69	3.50/4.10	38/40	0.33	CE UL

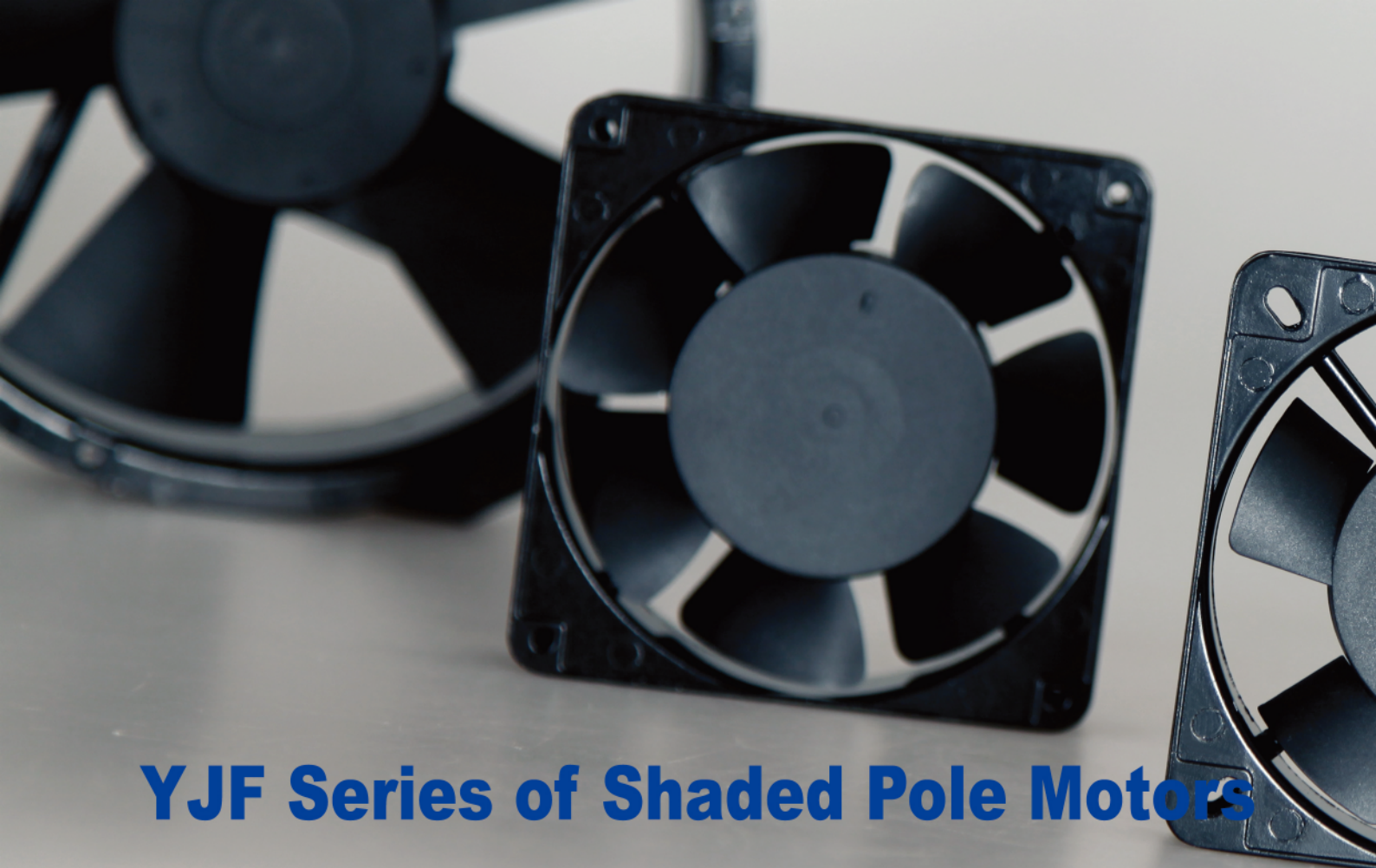

YJF Series of Shaded Pole Motors

YJF系列产品概述 Summary of YJF Series Shaded Pole Motors

- YJF系列微型罩极式风扇电机，具有结构紧凑、体积小、重量轻、噪音低、电磁干扰小、安全可靠、运行寿命长等特点。广泛运用于制冷设备、电子、焊接、电源、仪器仪表和通讯网络等设备的通风散热。
- 电机使用的所有原材料均通过RoHS认证。
- 电机适用环境温度：滚珠轴承：-20℃~60℃
含油轴承：0℃~50℃
- 电机平均使用寿命为20000小时以上。
- 大部分电机通过CCC、CE、UL认证。
- 电机使用前，必须将电机接地线与外部接地装置有效连接。
- YJF series mini-shaded pole fan motors have characteristics of compact structure, light weight, convenient installation, low noise, small disturbance, safety, longevity and so on. It mainly applied to refrigeration equipment, power supply circuit, electric welding machine as well as other ventilating and cooling equipment.
- All material conform to RoHS.
- The applicable ambient temperature:
Ball bearing: -20℃~60℃
Sleeve bearing: 0℃~50℃
- The average working life of motors is over 20000 hours.
- Most of motors get CCC, CE and UL.
- Make sure the earth wire of the motor connected with the external grounding device before operating.

型号说明 Illustration of Model

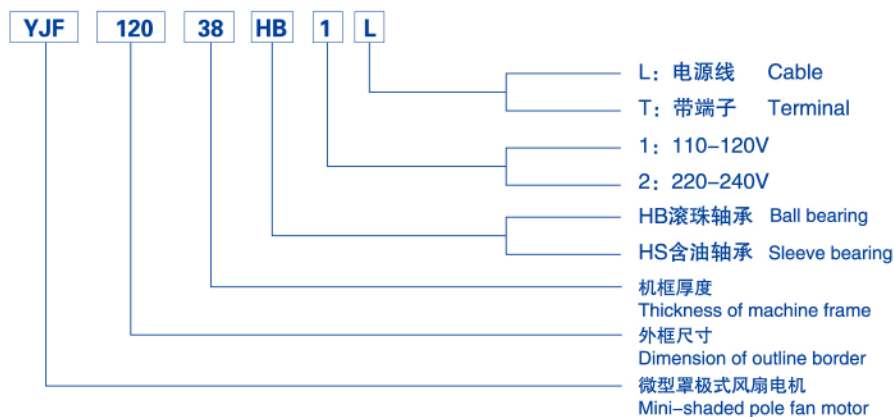

YJF-8025 罩极电机 Shaded Pole Motors

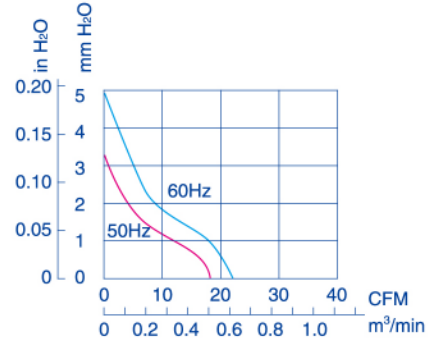
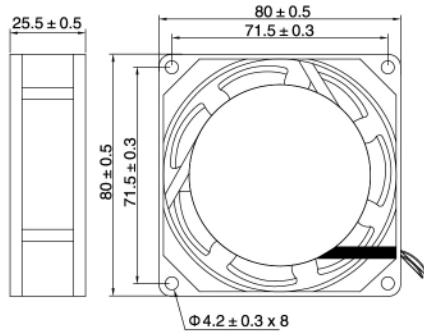

TYPE 型号	BEARING 轴承	LEAD WIRE 引出线	VOLTAGE 额定电压 V	FREQUENCY 额定频率 Hz	RATED INPUT 额定功率 W	RATED CURRENT 额定电流 A	SPEED 额定转速 r/min	AIR VOLUME 额定风量		STATIC PRESSURE 静压 mmH ₂ O	NOISE 噪音 dBA	NET WEIGHT 净重 kg	LICENSE 认证
								m ³ /min	CFM				
8025HB	BALL	CABLE	220~240	50/60	11/9	0.065/0.055	2500/2900	0.45/0.57	16/20	3.52/4.55	29/33	0.24	CE UL
8025HS	SLEEVE	CABLE	220~240	50/60	11/9	0.065/0.055	2300/2700	0.42/0.59	15/21	3.30/4.43	27/31	0.24	CE UL
8025HB	BALL	CABLE	110~120	50/60	12/11	0.12/0.10	2500/2900	0.45/0.57	16/20	3.52/4.55	29/33	0.24	CE UL
8025HS	SLEEVE	CABLE	110~120	50/60	12/11	0.12/0.10	2500/2900	0.45/0.57	16/20	3.52/4.55	29/33	0.24	CE UL

YJF-8038 罩极电机 Shaded Pole Motors

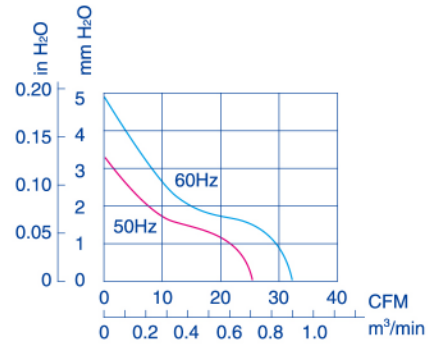
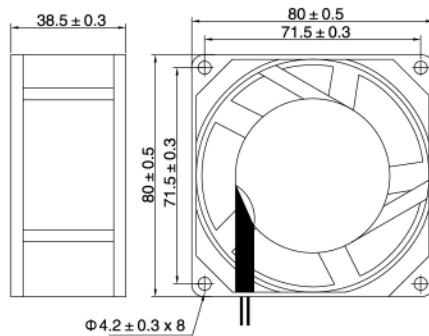

TYPE 型号	BEARING 轴承	LEAD WIRE 引出线	VOLTAGE 额定电压 V	FREQUENCY 额定频率 Hz	RATED INPUT 额定功率 W	RATED CURRENT 额定电流 A	SPEED 额定转速 r/min	AIR VOLUME 额定风量		STATIC PRESSURE 静压 mmH ₂ O	NOISE 噪音 dBA	NET WEIGHT 净重 kg	LICENSE 认证
								m ³ /min	CFM				
8038HB	BALL	CABLE/TERMINAL	220~240	50/60	13/10	0.10/0.08	2300/2700	0.59/0.71	21/25	2.92/4.32	30/34	0.3	CE UL
8038HS	SLEEVE	CABLE/TERMINAL	220~240	50/60	13/10	0.10/0.08	2300/2700	0.59/0.71	21/25	2.92/4.32	30/34	0.3	CE UL
8038HB	BALL	CABLE/TERMINAL	110~120	50/60	14/12	0.15/0.13	2400/2800	0.62/0.74	22/26	3.06/4.49	31/35	0.3	CE UL
8038HS	SLEEVE	CABLE/TERMINAL	110~120	50/60	14/12	0.15/0.13	2400/2800	0.62/0.74	22/26	3.06/4.49	31/35	0.3	CE UL

YJF-9225 單极电机 Shaded Pole Motors

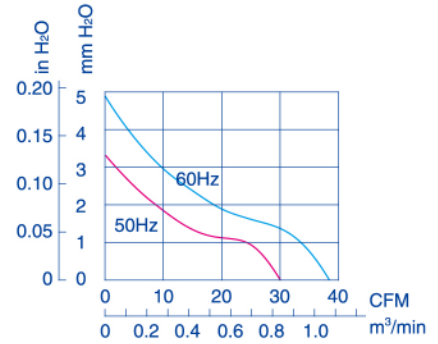
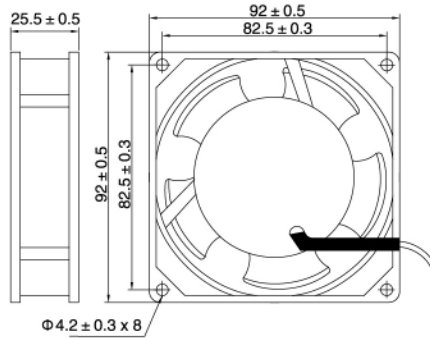

TYPE 型号	BEARING 轴承	LEAD WIRE 引出线	VOLTAGE 额定电压 V	FREQUENCY 额定频率 Hz	RATED INPUT 额定功率 W	RATED CURRENT 额定电流 A	SPEED 额定转速 r/min	AIR VOLUME 额定风量		STATIC PRESSURE 静压 mmH ₂ O	NOISE 噪音 dBA	NET WEIGHT 净重 kg	LICENSE 认证
								m ³ /min	CFM				
9225HB	BALL	CABLE/TERMINAL	220~240	50/60	11/9	0.065/0.055	2300/2600	0.68/0.82	24/29	3.50/4.50	30/34	0.28	CE UL
9225HS	SLEEVE	CABLE/TERMINAL	220~240	50/60	11/9	0.065/0.055	2300/2600	0.68/0.82	24/29	3.50/4.50	30/34	0.28	CE UL
9225HB	BALL	CABLE/TERMINAL	110~120	50/60	13/12	0.12/0.11	2500/2900	0.70/0.88	25/31	3.30/4.83	31/35	0.28	CE UL
9228HS	SLEEVE	CABLE/TERMINAL	110~120	50/60	13/12	0.12/0.11	2500/2900	0.70/0.88	25/31	3.30/4.83	31/35	0.28	CE UL

YJF-9238 單极电机 Shaded Pole Motors

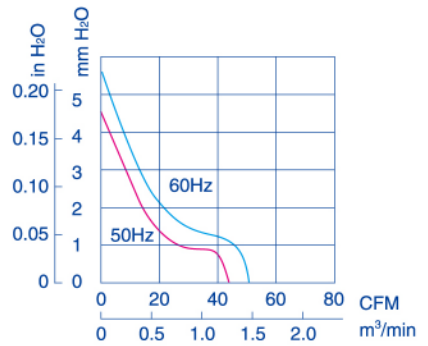
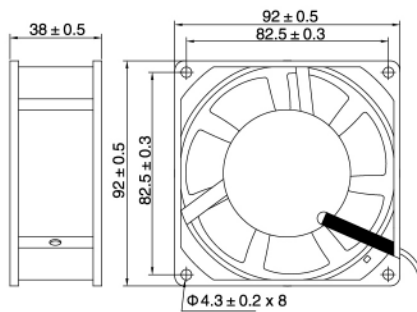

TYPE 型号	BEARING 轴承	LEAD WIRE 引出线	VOLTAGE 额定电压 V	FREQUENCY 额定频率 Hz	RATED INPUT 额定功率 W	RATED CURRENT 额定电流 A	SPEED 额定转速 r/min	AIR VOLUME 额定风量		STATIC PRESSURE 静压 mmH ₂ O	NOISE 噪音 dBA	NET WEIGHT 净重 kg	LICENSE 认证
								m ³ /min	CFM				
9238HB	BALL	CABLE	220~240	50/60	14/11	0.12/0.09	2500/3000	1.08/1.22	38/43	3.30/4.00	32/37	0.40	CE
9238HS	SLEEVE	CABLE	220~240	50/60	14/11	0.12/0.09	2500/3000	1.05/1.19	37/42	3.20/3.90	31/36	0.40	CE
9238HB	BALL	CABLE	110~120	50/60	18	0.22	2400	1.13	40	3.50	34	0.40	CE
9238HS	SLEEVE	CABLE	110~120	50/60	18	0.22	2400	1.13	40	3.50	34	0.40	CE